



FASTER



GREENER



SMARTER



RELIABLE

e-MP20
ELECTRIC PRESS



SACMI

Powder Metal Solutions

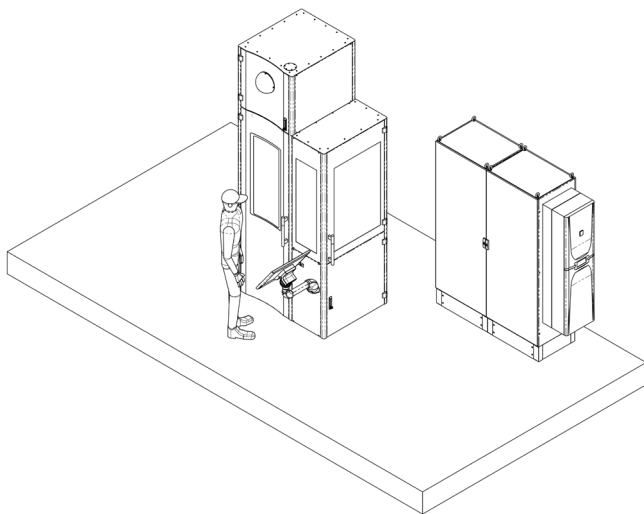
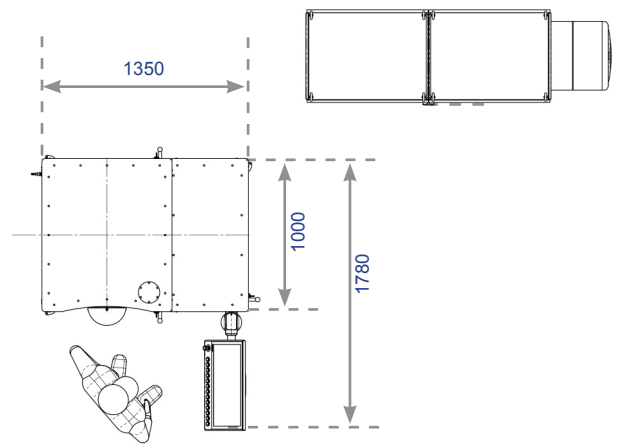
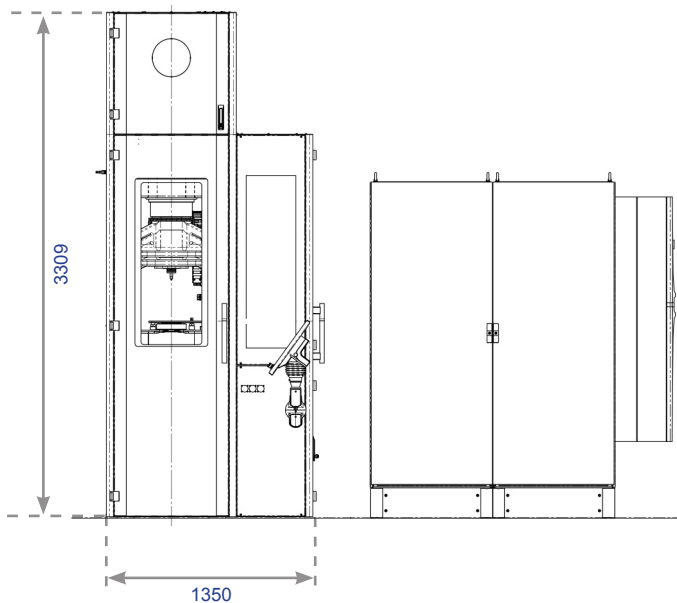

e-MP20

FULLY AUTOMATIC CNC PROGRAMMABLE
ELECTRIC PRESS FOR
POWDER COMPACTION

PRESSA ELETTRICA AUTOMATICA
PER POLVERI

CNC-GEREGLTE ELEKTRISCHE
PULVERPRESSE

TECHNICAL DATA - DATI TECNICI - TECHNISCHE DATEN

Upper level force Forza punzone superiore Presskraft Oberstempel	kN	200	Positioning accuracy Precisione di posizionamento Positioniergenauigkeit	mm	+/- 0,001
Upper level stroke Corsa punzone superiore Hub Oberstempel	mm	300	Filling height Altezza di caricamento Füllhöhe	mm	120
Lower level force Forza punzone inferiore Presskraft Unterstempel	kN	200	Core rod force Forza spina Kraft Dorn	kN	40
Lower level stroke Corsa punzone inferiore Hub Unterstempel	mm	150	Total weight Peso totale Gesamtgewicht	kg	4400

Other features (optional):

- Side compaction
- Full handling automation

Ulteriori caratteristiche (opzionali):

- Compattazione laterale
- Automazione completa

Weitere Eigenschaften (optional):

- Querpressen
- Komplette Automation



SACMI IMOLA S.C.
Via Selice Prov.le, 17/A - 40026 Imola Bo - ITALY
Tel. +39 0542 607995 - powdermetal@sacmi.it
www.sacmi.com - www.powdermetalpresses.com

